

ELEVATOR DEFLECTION STOP UPDATE: MARCH 2008

The following is an approved modification to limit elevator deflection per Chris Heintz letter dated 25 March, 2008.

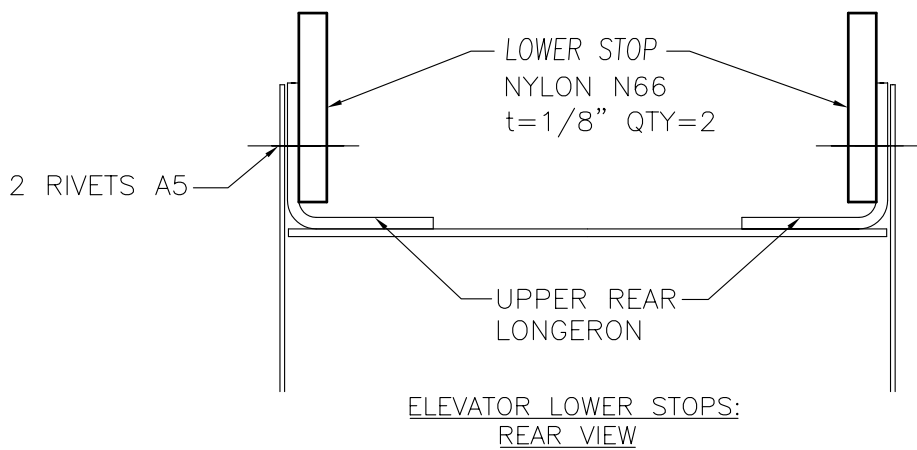
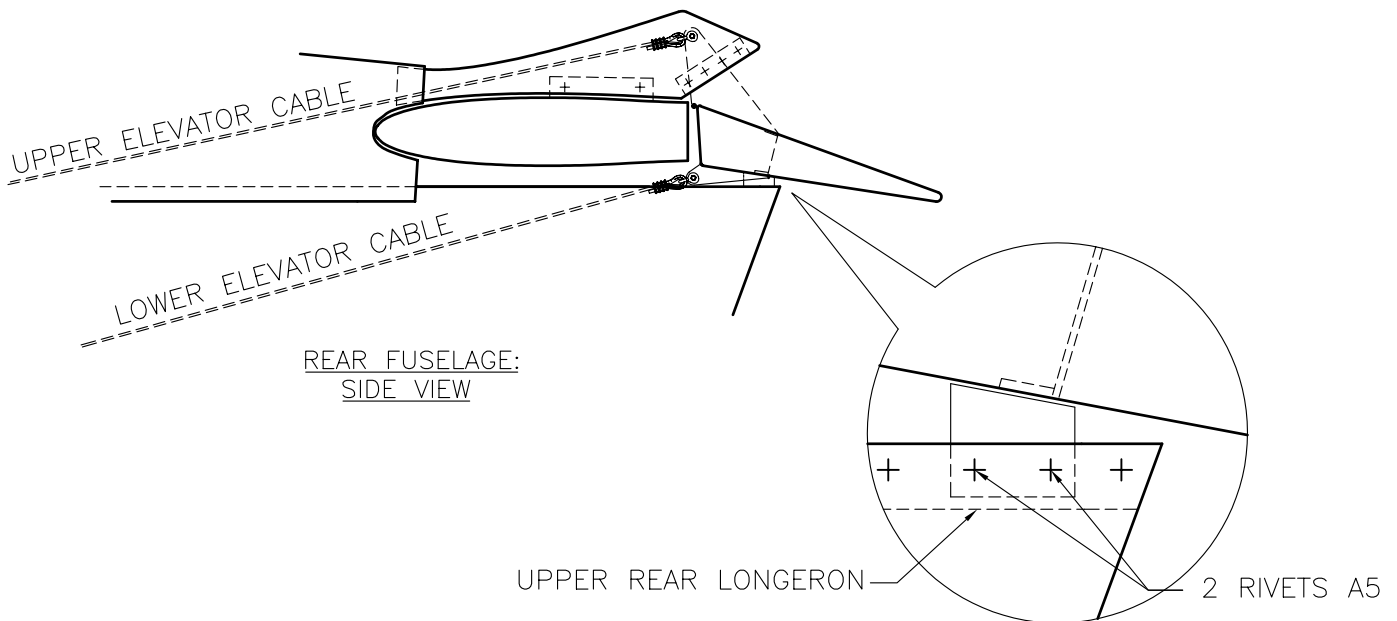
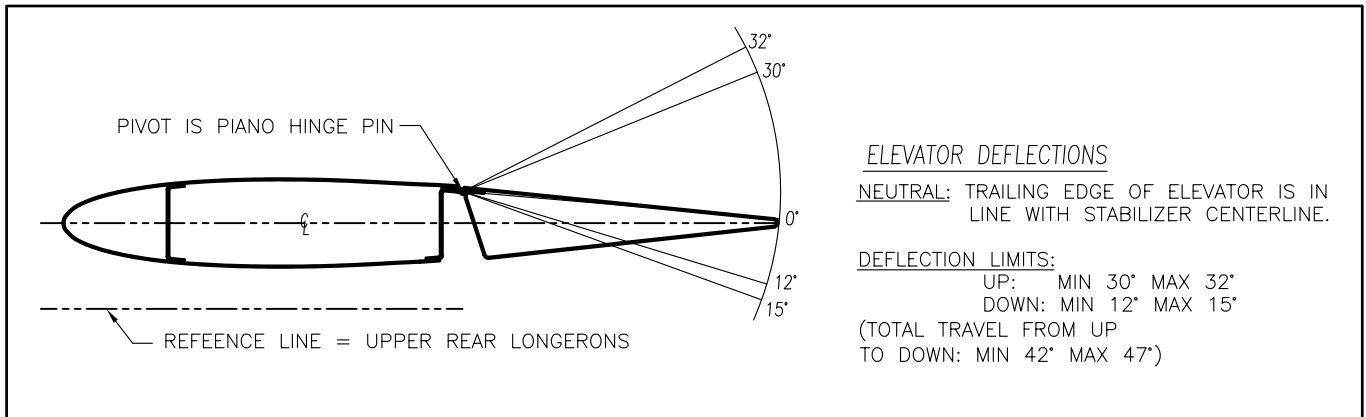

REFERENCE: - Chris Heintz LETTER DATED 25 MARCH, 2008
 - "CONSTRUCTION STANDARDS FOR ZENAIR LIGHT AIRPLANES"
 - ZODIAC DRAWINGS AND MANUALS

| | | |
|---|---|--|
| <p>MODEL NO. ZODIAC CH 601</p> | <p>DESCRIPTION: ELEVATOR DEFLECTION LIMITS</p> <p>COPYRIGHT © 2008 Chris Heintz DATE: 03/08</p> | |
|---|---|--|