

December 17, 2004

Dear ZODIAC XL builder:

Upon inspection of several aircraft it's come to my attention that the original nosewheel fork of the Zodiac XL is quite flexible with side loads, and that cracks may begin to form in the nosewheel fork bend radius over time or with excessive side loads. If a nosewheel fairing is installed it may be difficult to inspect for cracks.

I recommend that a nosewheel fork doubler be installed as shown below:

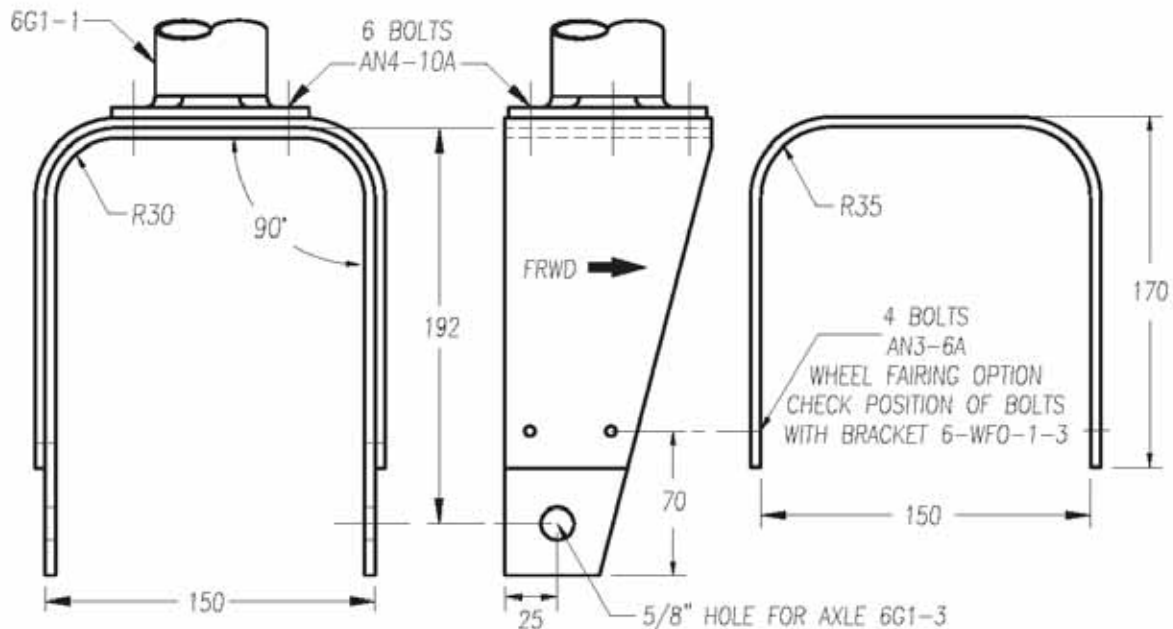

6G1-5 FORK DOUBLER
t=3/16" 6061-T6 (1 REQ'D)
COLD BEND

The nosewheel fork doubler, part no. 6G1-5, can be ordered from Zenith Aircraft Co. for \$32.50 with the installation hardware, and for \$40.00 including shipping and handling within the USA.

If you have sold your kit or aircraft, please forward this letter to the new owner. Contact me if you have any questions regarding this, or contact Zenith Aircraft Company.

Regards,

Chris Heintz,
Designer.

ZENITH AIRCRAFT COMPANY

Mexico Memorial Airport, PO Box 650, Mexico, Missouri 65265-0650 USA
 573-581-9000 FAX: 573-581-0011 www.zenithair.com

ORDER FORM

Aircraft Model: ZODIAC XL	Serial No: 6 -	Day Telephone:
Name:		Home Telephone:
		Email:
Mailing Address:	Shipping Address:	
Signature of Buyer(s):		Date:

ITEMS: AMOUNT

6G1-5 Nosewheel Fork Doublor with Installation Hardware	\$ 32.50

NOTES / SHIPPING INSTRUCTIONS:	TOTAL OF ABOVE:	
	APPLICABLE SALES TAX:	
	CRATING / HANDLING: (Prices F.O.B. Factory)	7.50
	TOTAL:	\$ 40.00

Thank you for your order. Call (573) 581-9000 if you need assistance with this order.

All prices in U.S. Funds.
 Availability, Prices and Conditions subject to change without prior notice. © Zenith Aircraft Company (2004).
 Downloaded from www.zenithair.com Email questions to: orders@zenithair.com

Amount: \$ _____	Check #: _____
Visa MasterCard: _____ - _____ - _____ - _____	Exp: ____ / ____

Date Rec: _____ By: _____ Ship Date: _____